

PRESS RELEASE

FOR IMMEDIATE RELEASE

June 28 2007

CONTACT: DAVE GRABOSKI/BOB LEWEN

**SBV2, SBV2 "Pro" and STR4 Pro II
Heavy Duty Ball Diff Hub (Steel Outdrives).**

98VP T001

Heavy Duty Ball Diff. Hub
(Steel Outdrives)

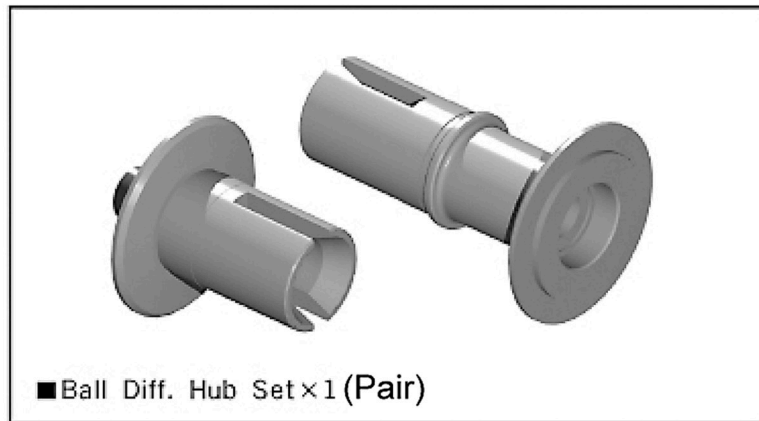

ADVANTAGES:

- Longevity of differential smoothness is increased, making for a better handling racecar
- Drive pins will not wear the outdrive yoke nearly as fast, producing a smoother suspension throughout shock travel.
- Produces less drivetrain flex under load, which makes for a more consistent internal gear mesh.
- Allows slipper clutch (V2 Series) to be run tighter for instantaneous acceleration

Retail: \$22.00

Available Late July